



**eXploration Habitat (X-Hab)  
Academic Innovation Challenge  
Solicitation**

on behalf of

NASA Headquarters  
Exploration Systems Mission Directorate,  
Directorate Integration Office and  
Innovative Partnerships Program Office  
The Habitat Demonstration Unit Project

Release Date: June 23, 2010  
Notice of Intent Due: July 23, 2010  
Proposals Due: August 20, 2010  
Anticipated Award Date: August 30, 2010  
Program Website: <http://www.spacegrant.org/xhab/>

## Table of Contents

1. Synopsis .....	1
2. Eligibility.....	2
3. Funding Opportunity Description .....	2
3.1. Description.....	2
3.2. Background and Purpose .....	3
3.3. Technical Interchange Meetings.....	4
3.4. Pertinent Dates.....	4
3.5. Documentation and Deliverables.....	5
3.6. Period of Performance.....	5
3.7. Facilities and Equipment .....	5
4. Proposal and Submission Information .....	5
4.1. Proposal Format and Content .....	5
4.2. Proposal Evaluation Criteria .....	6
4.3. Proposal Submission.....	7
Appendix A: Budget Summary.....	8
Appendix B: "Exploration Habitat Inflatable Loft" Requirements and Competition Evaluation Criteria ...	10
Appendix C: Standard Education Grant/Cooperative Agreement.....	15
Appendix D: Certifications and Assurances.....	16

## 1. Synopsis

The X-Hab Academic Innovation Competition is a university level competition designed to engage and retain students in Science, Technology, Engineering and Math (STEM) disciplines. NASA will directly benefit from the competition by sponsoring the development of innovative habitat inflatable loft concepts from universities which may result in innovative ideas and solutions that could be applied to exploration habitats. The challenge is for a senior and/or graduate level design course in which students will design, manufacture, assemble, and test an inflatable loft that will be integrated onto an existing NASA built operational hard shell prototype (figure 1). In June of 2011 the NASA-Habitat Demonstration Unit (HDU) Project will conduct a head-to-head competition for successfully designing and demonstrating an attachable inflatable habitat "Loft" (2<sup>nd</sup> level attachable) concept given a list of requirements for the design. Universities may collaborate together on a Project Team. Up to three project teams will be selected for funding. The head-to-head competition will determine the winner that will be awarded additional funds to integrate their design with the HDU-Lab during the August-September 2011 HDU-Hab/Lab integrated field testing. The objectives of this challenge are to engage and inspire the next generation of innovative engineers and the successful design, manufacture, and demonstration of inflatable habitat loft. Concepts are to be self-deploying in a specified time, will install to a standard interface on NASA's hard shell Lab (figure 2), and will meet total mass and volume constraints in both stowed and deployed configurations. Concept shapes and sizes will be determined by the proposer while meeting the constraints of the design requirements.



Figure 1: FY10 HDU-Lab Unit

The Foundation anticipates that up to three awards will be made under this solicitation for \$48,000 each. Up to an additional \$10,000 will be awarded to the team that wins the head-to-head competition to offset their costs of participating in the HDU-Hab/Lab integrated field testing.

## **2. Eligibility**

Proposals will be accepted from faculty who are U.S. citizens and currently teach an ABET accredited engineering senior or graduate design, industrial design, or architecture curriculum teaming course at a university affiliated with the National Space Grant College (if applicable) and Fellowship Program, or other US accredited university. Multi-discipline, multi-departmental, and/or multi-institutional teaming collaborations are highly encouraged.

Historically Black Colleges and Universities, Tribal Colleges and other minority serving educational institutions are particularly encouraged to apply. Proposals from women, members of under-represented minorities groups, and persons with disabilities are highly encouraged.

## **3. Funding Opportunity Description**

### ***3.1. Description***

NASA's multi-center Habitat Demonstration Unit Project is requesting proposals for the inaugural eXploration Habitat (X-Hab) Academic Innovation Challenge. This academic challenge will build on the NASA built 5 meter diameter Pressurized Excursion Module (PEM) hard shell that has been outfitted with hardware, software and workstations in for an operational surface habitat demonstration unit. The X-Hab Challenge is a university based head-to-head competition to design, manufacture, assemble, test, and demonstrate an inflatable loft. The winner of the competition will participate in the 2011 Desert Research and Technology Studies (DRaTS) August-September 2011 or equivalent field test demonstration.

NASA's Habitat Demonstration Unit Project is inviting university faculty who teach design courses to submit a proposal based on the design and manufacturing of an inflatable habitat loft and its utilities and outfitting concepts within a two-semester, ABET accredited, design course. Design projects are intended to stimulate undergraduate and graduate research on current NASA habitation activities and to bring out innovative and novel ideas that can be used to complement those currently under development at respective NASA Centers. Additionally, such academic involvement will improve the prospects for graduates to pursue additional studies and to seek careers in the space industry. The design course will be focused on a planetary exploration excursion habitat. It is understood by NASA that the funding awarded to manufacture the loft inflatable may not be sufficient to manufacture the inflatable and thus it may be required for teams to secure supplemental sponsored funding in order to design, manufacture, assemble, test, and demonstrate a functional and operational test article. As part of this solicitation the universities are encouraged to innovatively seek additional sponsorship and collaborations (Project Teaming) with other universities and organizations to meet the design requirements and test objectives. Each proposal must include a signed commitment from the university faculty, collaborators, and their potential sponsor(s) to ensure their commitment to the project.

NASA has built and tested a 2010 surface Habitat Demonstration Unit (HDU) Pressurized Excursion Module (HDU-PEM) laboratory that will be utilized to advance NASA's understanding of alternative mission architectures, requirements definition and validation, and operations concepts definition and validation. The HDU-PEM will support a crew of 4 for a minimum of 14 days and up to 60 days. The HDU-PEM is a 5-meter diameter hard shell vertically-oriented one-story module with four ports/hatches. Its development testing begins in August 2010 with a field analog test as an excursion laboratory. With the expanded volume of the inflatable loft the HDU Project will add habitation functionality as part of testing a HDU-Hab/Lab unit in 2011.

University professors who are interested should propose an X-Hab Academic Innovation Challenge notional design study that they would like to develop. They must conform to the end-product design requirements and meet the evaluation criteria.

The selected project teams will implement the design course during the fall 2010 and spring 2011 semester. All teams must provide proof that the course has been approved to be taught at their institution in 2010-2011 academic year. The selected professor must be available for technical assistance to the implementing universities during the 2010-2011 academic year.

Applicants are required to apply a systems engineering approach for the design course. For reference please see the NASA Systems Engineering Handbook NASA SP-2007-6105.

The following project review milestones will take place with participation from the NASA-HDU Project Team

- Sept 30 – Concept and System Definition Review
- Oct 30 – Preliminary Design Review
- Nov 30 – Critical Design Review
- Feb 14 – Progress Checkpoint Review #1
- April 1 – Progress Checkpoint Review #2

### **3.2. Background and Purpose**

The Exploration Systems Mission Directorate (ESMD) is dedicated to creating a constellation of new capabilities, supporting technologies and foundational research that enables sustained and affordable human and robotic exploration. NASA delivers a comprehensive Agency education portfolio, implemented by the Office of Education, the mission directorates, and the NASA field centers. Through the portfolio, NASA contributes to our Nation's efforts in achieving excellence in science, technology, engineering and math (STEM) education. Three outcomes serve to align all Agency education activities. This announcement maps to Outcome 1: Contributing to the development of the STEM workforce in disciplines needed to achieve NASA's strategic goals.

The purpose of the X-Hab Academic Innovation Challenge is to train and develop the highly skilled scientific, engineering, and technical workforce of the future needed to implement the U.S. Space Exploration Policy.

The following area is critical to the future of space exploration.

**Lunar and Planetary Surface Systems-** Precision landing hardware, software, in-situ resource utilization (ISRU), navigation systems, extended surface operations, robotics, (specifically environmental scouting prior to human arrival, outpost maintenance with and without humans present, and assist astronaut with geologic exploration) environmental analysis, radiation protection, spacesuits, light-weight structures, life support and habitation, and power systems.

The HDU Project has five main objectives for the Academic Challenge:

1. Teams will learn by putting into practice the knowledge and skills they have gained throughout their years at their respective university.
2. Teams will analyze and solve complex design and integration issues from an interdisciplinary perspective, exercising their innovation and initiative as they deal with conflicting requirements and make appropriate trade-offs.

3. Teams will develop skills in project teamwork, leadership, critical thinking, and decision-making in an academic environment.
4. Teams will produce a Hab-loft and a final report that will be made widely available to space agencies, aerospace companies and universities.
5. This support will adhere to NASA's commitments in its Strategic Plan to "maintain strong partnerships with academia" and to "engage and inspire students."

### **3.3. Technical Interchange Meetings**

Prior to the proposal submission deadline, two Technical Interchange Meetings (TIM) will be held with the NASA HDU Project to answer questions about the project. Questions pertaining to this effort shall be submitted 4 days prior to TIM #1 and TIM #2. Answers will be published on the website and discussed at the TIMs.

Schedule:

TIM #1: July 8, 2010 @ 3:00 – 4:00 PM CDT

TIM #2: July 29, 2010 @ 3:00 – 4:00 PM CDT.

Questions must be submitted to [xhab@spacegrant.org](mailto:xhab@spacegrant.org) at least four days prior to the TIM. Answers will be published on the website and discussed at the TIMs. The TIM call in number will be published on the program website.

### **3.4. Pertinent Dates**

June 23, 2010	Date of Announcement
July 4, 2010	Questions for TIM #1 Due
July 8, 2010	Technical Interchange Meeting Telecon #1
July 23, 2010	Notice of Intent Due
July 25, 2010	Questions for TIM #2 Due
July 29, 2010	Technical Interchange Meeting Telecon #2
August 20, 2010	Proposal Due Date
August 30, 2010	Award Announcements
Fall 2010	Design Phase
September 30, 2010	Concept and Systems Definition Review
October 30, 2010	Preliminary Design Review
November 30, 2010	Critical Design Review
Spring 2011	Manufacturing, Assembly, and Testing Phase
February 14, 2011	Progress Checkpoint Review #1
April 1, 2011	Progress Checkpoint Review #2
June 20-24, 2011	Head to Head competition at NASA/JSC
July - Aug 2011	Integration with HDU-Lab
Aug - Sept 2011	Field Testing

### **3.5. Documentation and Deliverables**

Award recipients will provide the following deliverables:

- Work Plan and Implementation Schedule
- Participation in Milestone Progress Reviews (WebEx & Telecon)
- Report on Educational Outreach activity
- Inflatable Loft Prototype Demonstration Unit
- Inflatable Loft Technical Final Report

### **3.6. Period of Performance**

The period of performance for this award will be September 1, 2010 to August 31, 2011. The contract for the head-to-head competition winning team will be extended to facilitate participation in the field testing.

### **3.7. Facilities and Equipment**

Facilities and equipment needed to conduct this X-Hab Academic Innovation Challenge are the responsibility of the proposing project team and respective Universities. No unique facilities, U.S. Government-owned facilities, industrial plant equipment, or special tooling are required. The packaged inflatable loft shall be capable of being lifted into place by a crane for attachment to the HDU Interface Ring.

## **4. Proposal and Submission Information**

### **4.1. Proposal Format and Content**

Proposals should be single-spaced on standard 8 ½ x11 paper, no smaller than 12 point font and with one inch margins throughout. All proposals must be prepared in the following format:

1. **Title Page** (not included in the page count) - Title of X-Hab Academic Innovation Challenge, name and contact information of proposing faculty (address, university affiliation, email address, phone number), and the local Space Grant Consortium (if applicable) in which faculty is affiliated.
2. **Body of Proposal** (8 pages maximum)
  - **Proposal Synopsis** – description of the X-Hab Academic Innovation Challenge work plan, design challenge to the students, and complexity.
  - **Significance**- description of the need and relevancy of the proposed design project for NASA, and how this course will benefit the university.
  - **Content** – description of the course outline, framework, and the faculty outline. Applicants should describe the involvement of appropriate computer-aided tools in its design and analysis solution. Applicants should describe how a Systems Engineering process will be applied. Applicants should propose a preliminary notional concept and layout of the Inflatable Loft with the understanding the final design will occur during the fall semester.
  - **Mechanisms for integration**- description of how the X-Hab prototype will be integrated and tested at the affiliated university in academic year 2010-2011. Applicants should also describe the feasibility of implementing the project team with other universities, if applicable.

- **Diversity:** Demonstrate effort to attract a diverse group of student participants, including underrepresented and underserved minorities, women, and students with disabilities, along with multiple academic disciplines. Disciplines include an engineering, industrial design, and architecture curriculums.
- **Educational Outreach Plan** - plan for the engagement of K-12 students from the local community through presentations, team involvement, mentoring, etc.
- **Assessment Plan** – plan for evaluation approach of design course, lessons learned, and potential impacts.
- **Past Performance-** demonstration of successful implementation of design courses that met ABET quality standards. Applicants should also demonstrate experience with a systems engineering process.
- **Resources (Sponsors)** – includes sponsorships, leveraging opportunities, unique capabilities, matching funds, and in-kind support. Also may include collaborations with other Universities.

3. **Schedule (not included in the page count)** - one-page overview of the proposed schedule should include the deliverables, expected dates of tangible outcomes, travel dates and final report to NASA.

4. **Budget (not included in the page count)** - total NASA funding requested cannot exceed \$48,000. Specific information should be given for salary, detailed expenses for supplies and materials for the course and for the project, expenses for workshop and travel (to JSC for the head-to-head competition June 2011). Specific information should be given pertaining to supplemental funding by sponsors and collaboration showing estimated expenditures. Reduction or full waiver of indirect costs are encouraged and may be considered as an University contribution to the project.

5. **Appendix** (not included in the page count)-

- **Mandatory-** a signed confirmation of support of the proposal must include a signed commitment from the University faculty, collaborators, and their potential sponsor(s) to ensure their commitment to the project.
- **Mandatory-** a signed confirmation from the university stating that the X-Hab Academic Innovation Challenge will be implemented during the 2010-2011 academic year.

#### **4.2. Proposal Evaluation Criteria**

The X-Hab Challenge is divided into two phases. Phase-1 solicits proposals that will be evaluated and up to three (3) X-Hab Loft project teams selected for the Phase-2 head-to-head competition. Both phases will be evaluated based on appropriate predetermine evaluation criteria.

#### **Phase-1 Evaluation Criteria**

The following criteria will be used in the Phase-1 proposal evaluation process:

#### **Mandatory Logistics**

- Identify Project Title
- Identify Project Team
- Identify the Principal Investigator (PI)
- Identify a Vision, Mission, and Concept of Operations
- Identify the Problem Statement, Functional and Performance Requirements
- Identify a Work Plan, Integration Testing Plan, Milestone Schedule, and Experience.
- Identify faculty institution and provide confirmation of commitment in appendix.
- Identify a Research Assistant to provide leadership to the student project team.
- Identify affiliated Space Grant Consortium (if applicable), Sponsor, or Affiliations.

- Identify NASA Technical Expert and provide signed statement of commitment in appendix.
- Identify manufacturing, assembly, and pre-testing capabilities and facilities.
- Identify a preliminary notional concept and layout of the Inflatable Loft with the understanding the final design will occur during the fall semester.

#### **Merit**

- Demonstrate alignment with NASA ESMD objectives.
- Describe work plan to implement and integrate project into university.
- Demonstrate alignment with ABET quality standards.
- Include systems engineering process in the course.
- Include appropriate computer-aided design and analysis tools in the course.
- Provide evidence of past performance of design courses that meet ABET quality standards.
- Provide feasibility of project teaming implementation with other universities.

#### **Contribution to NASA Workforce Development**

- **Content:** Demonstrate ability to develop a meaningful, challenging, realistic hands-on ESMD-relevant design project.
- **Continuity:** Demonstrate ability to create interest in NASA while connecting and preparing students for the workforce.
- **Diversity:** Demonstrate effort to attract a diverse group of student participants, including underrepresented and underserved minorities, women, and students with disabilities, along with multiple academic disciplines. Disciplines include an engineering, industrial design, and architecture curriculums.
- **Education Outreach:** Demonstrate effort to engage K-12 students in the local community
- **Evaluation:** Provide assessment plan including appropriate quantitative metrics and qualitative outcomes.
- **Budget:** Provide adequate, appropriate, reasonable, and realistic budget.

#### **Phase-2 Evaluation criteria**

For details pertaining to the solicitation, design requirements and evaluation criteria please see Appendix B: Exploration Habitat Inflatable Loft" Requirements and Competition Evaluation Criteria below.

#### **4.3. Proposal Submission**

Although not required, it is highly encouraged that prospective proposers submit a notice of intent to [xhab-noi@spacegrant.org](mailto:xhab-noi@spacegrant.org) by July 23, 2010.

Electronic copies of proposals must be received no later than: **midnight Pacific Daylight Time, Friday, August 20, 2010**. Late proposals will not be considered. The proposal will be submitted online at <https://secure.spacegrant.org/proposals/xhab/>

Applicants will be advised by electronic mail when selections are made. It is anticipated that the award will be announced on August 30, 2010.

## Appendix A: Budget Summary

From \_\_\_\_\_ To \_\_\_\_\_

	Funds Requested from Sponsor	Proposed Cost Sharing (if any)
1. Direct Labor	\$ _____	_____
2. Other Direct Costs:		
a. Subcontracts	\$ _____	_____
b. Consultants	\$ _____	_____
c. Equipment	\$ _____	_____
d. Supplies	\$ _____	_____
e. Travel	\$ _____	_____
f. Other	\$ _____	_____
3. Indirect Costs	\$ _____	_____
4. Other Applicable Costs	\$ _____	_____
5. Total	\$ _____	_____
6. Total Estimated Costs	\$ _____	_____

## Budget Narrative

If the proposal contains cost sharing separate budget narratives should be included for the funds requested from the sponsor and the proposed cost sharing.

1. **Direct Labor** (salaries, wages, and fringe benefits): Should list numbers and titles of personnel, amount of time to be devoted to the grant, and rates of pay.
2. Other Direct Costs:
  - a. **Subcontracts** - Describe the work to be subcontracted, estimated amount, recipient (if known), and the reason for subcontracting this effort.
  - b. **Consultants** - Identify consultants to be used, why they are necessary, the time they will spend on the project, and rates of pay (not to exceed the equivalent of the daily rate for Level IV of the Executive Schedule, exclusive of expenses and indirect costs.)
  - c. **Equipment** - List separately and explain the need for items costing more than \$1,000. Describe basis for estimated cost. General purpose equipment is not allowable as a direct cost unless specifically approved by the sponsor.
  - d. **Supplies** - Provide general categories of needed supplies, the method of acquisition, estimated cost. (For Example: Office Supplies, Lab Supplies, etc.)
  - e. **Travel** - List proposed trips individually and describe their purpose in relation to the award. Also provide dates, destination, and number of people where known. (For example: Airfare, Hotel, Per Diem, Registration, Car Rental, etc.)
  - f. **Other** - Enter the total direct costs not covered by 2.a through 2.e. Attach an itemized list explaining the need for each item and the basis for the estimate.
3. **Indirect Costs**
4. **Other Applicable Costs** - Enter the total of other applicable costs with an itemized list explaining the need for each item and basis for the estimate.
5. **Total** – The sum of lines 1 through 4.
6. **Total Estimated Costs** – The sum of the funds requested from the sponsor and the proposed cost sharing (if any)

## Appendix B: "Exploration Habitat Inflatable Loft" Requirements and Competition Evaluation Criteria

Offer up a competition for successfully designing and testing an attachable inflatable habitat "Loft" (2<sup>nd</sup> level attachable) concept given a list of functions to be included in the design. Concept shall include the concept layout, is to be self-deploying in a specified time, will have to use predetermine standard interfaces (figure 2) to NASA hard shell habitat demonstration unit, and total mass and volume constraints both in stowed and deployed configurations. Points will be given for most effective use of space. The objectives of this challenge are the successful design and evaluation of inflatable habitat augmentation, given a list of functions to be included in the design (space for crew habitation, sleeping area, meeting area, transfer and storage of crew logistics). Concepts shall be self-deploying in a specified time and will have to use predetermine standard interfaces to NASA hard shell habitat, and total mass and volume constraints both in stowed and deployed configurations. The HDU will provide the inflatable loft structural interface, loft floor, and a removable set of safety handrails. The interface drawings for the HDU top interface ring are included here-in. More detailed drawing will be made available after team selection. The habitation outfitting shall be functional and load bearing (e.g. no foam core or card board).

Inflatable Loft Habitation functionality to be included:

- Provide Sleeping Accommodations for 4 crew (propose private or shared, acoustic privacy)
- Provide Power to Sleeping Areas (via HDU source)
- Provide Integrated Lighting (via HDU power source)
- Provide Air Circulation (HVAC via HDU source)
- Provide Personal Crew Items Stowage
- Provide Group meeting function
- Provide crew stowage items translation into loft function

Expandable habitat "Inflatable Loft" requirements:

1. Perform the function of additional habitable volume for sleeping and crew gathering as described in the "Inflatable Loft Habitation functionality" listed above. Concept floor plan.
2. Materials used should function as an analog for the final materials that would be adapted to space qualification. Can use nylon or similar fabrics that are of equivalent weight and construction that will simulate flight like materials such as Vectran.
3. A structural analysis shall be done of the shell flight configuration designed to support 8.3 psid with a SF = 4.0. This shell flight configuration shall be documented in the report.
4. The demonstration unit fabric structure shall be capable of being inflated to a minimum low pressure (approx. 0.125 psid) that is capable of supporting the weight of the fabric, pre-integrated window, and wind loading of 50 miles per hour (mph). A (2.0 X 0.125 psid) proof test will be required prior to the HDU and loft integration.
5. Interface with the HDU "Barrel Interface Ring," figure 2. Develop an interface **ring** (it may be or may not be segmented) that is pre-integrated to the inflatable shell (fits in a folded package) such that when mated to the top surface of the HDU as a complete ring, meets a low leak rate requirement and structural loading requirements. There shall be **no visible damage of the bladder** should be present at the sealing interface.
6. Provide an Inflation System to perform initial deployment and delta inflation as required.
7. Single Story.
8. Minimum deployed volume is 60 m<sup>3</sup>.
9. Pre-Integrated Utilities (air circulation, power, and lighting).
10. Pre-Integrated window. Window size 0.5 meter diameter.
11. Maximum weight including interface hardware is ~**500 kg**.

12. Provide simulated micrometeoroid / secondary ejecta (MM/SE) and radiation protective layers, Assume a 2-layer Lunar MM/SE bumper shield with a mass of (CxAT Lunar Analysis MMSE = 1.52 kg/m<sup>2</sup>) 1.5 kg/m<sup>2</sup>
13. Provide multi-layer thermal insulation equivalent to an R-value of no less than R=16.
14. Expandable structure shall be self-supporting when crew is translating into or out of the HDU to Loft.
15. Shall be capable of re-packaging from the deployed configuration to the package configuration.

**Phase-2 Inflatable Loft Evaluation Criteria:**

1. Packaging Ratio: lowest packaged to deployed volume.
2. Deployment to Re-packaged Unit.
3. Least mass to deployed volume.
4. Deployment: Transportation and Handling, Time to Install and Deploy, Autonomous Deployment.
5. Effective use of Space/Volume and Habitability Crew Comfort.
6. Lowest pressure decay per hour.
7. Self-supporting due to loss of internal atmosphere.

Figure 2. "HDU Inflatable Loft" Interface Ring Details

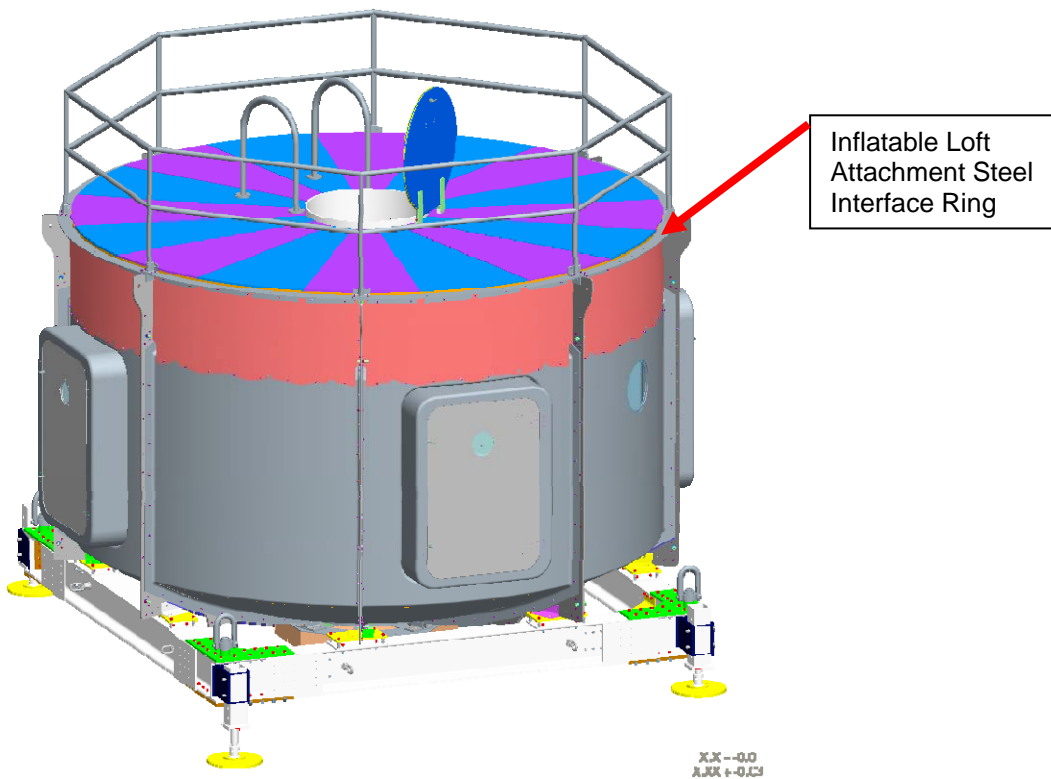

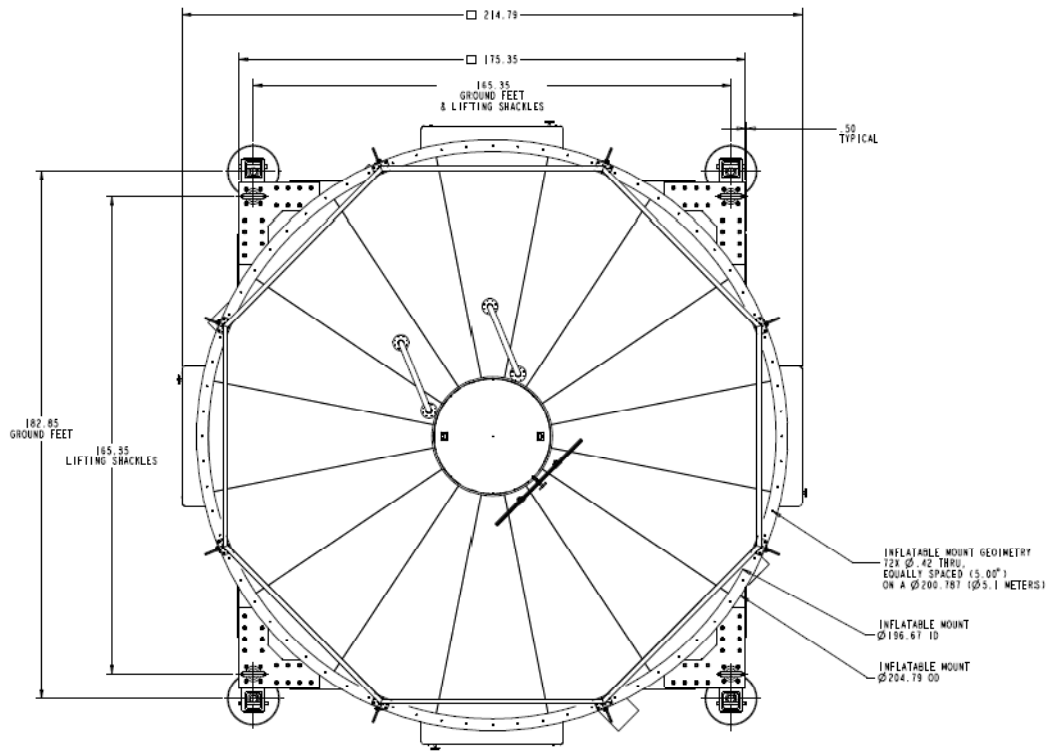
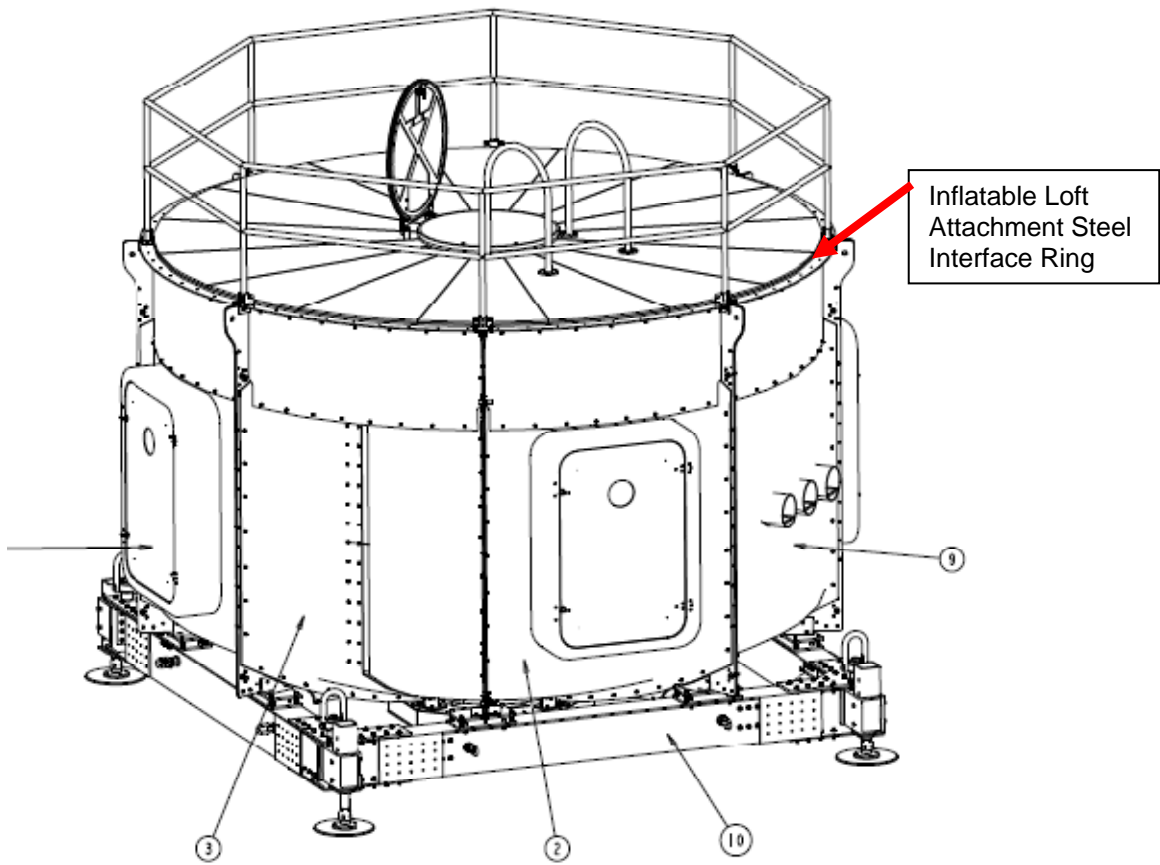

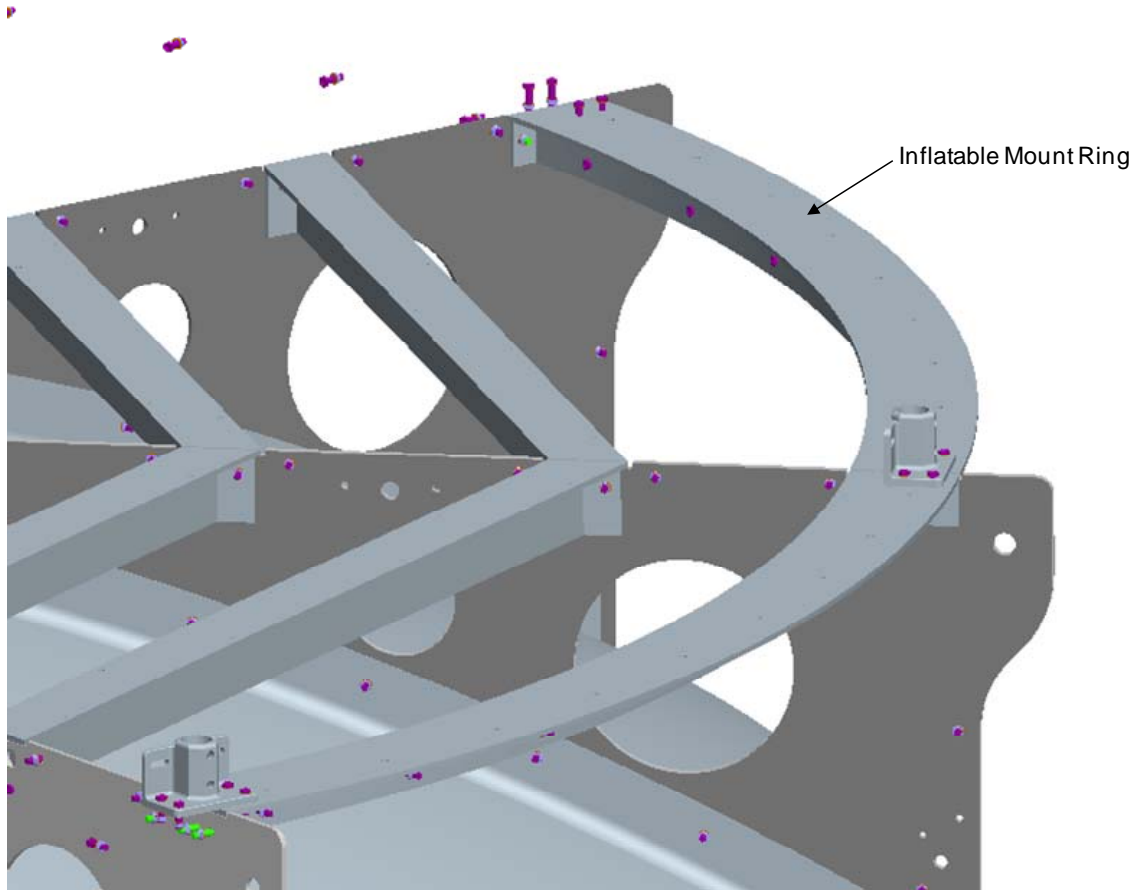

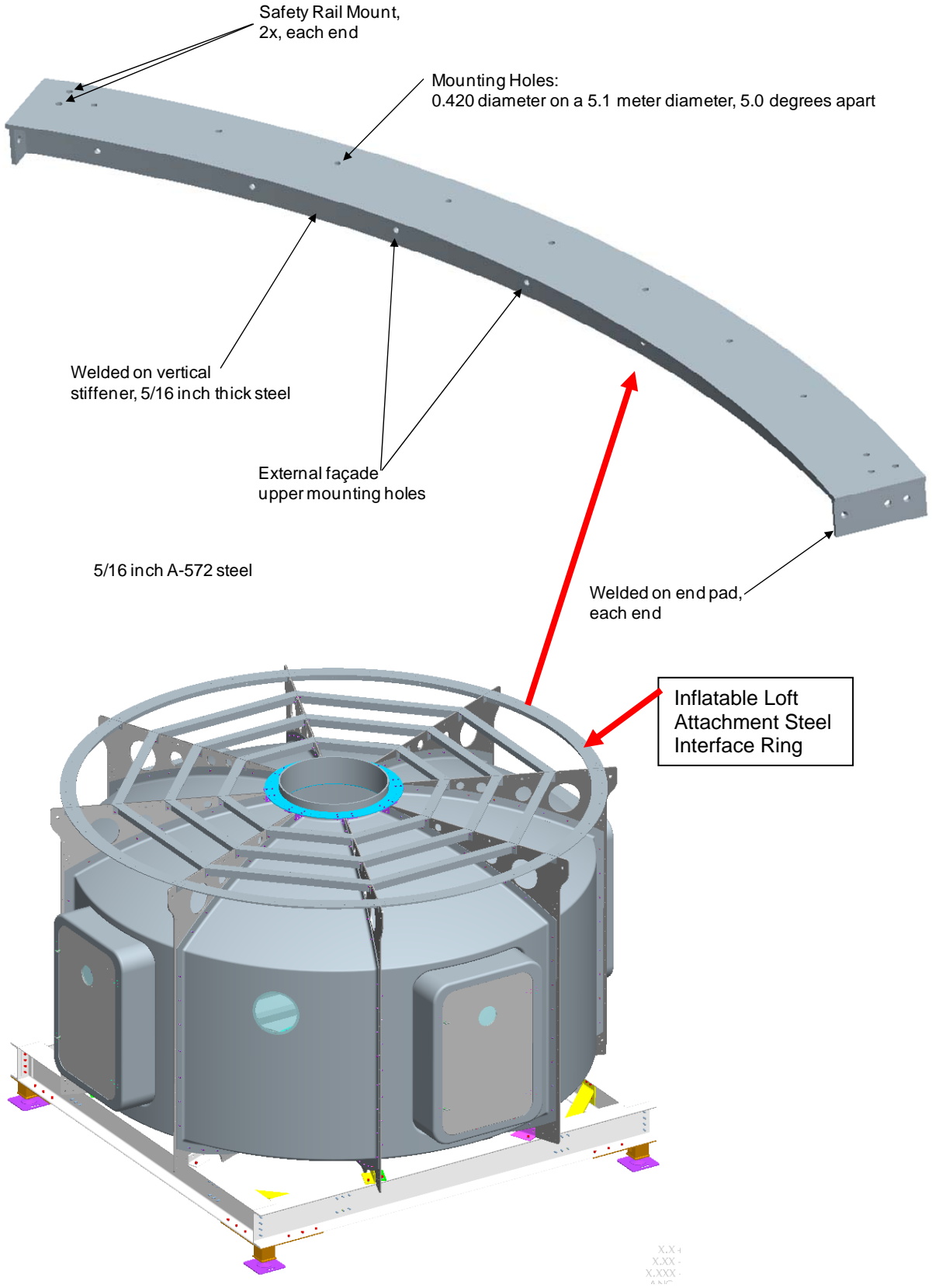

## Appendix C: Standard Education Grant/Cooperative Agreement

The following provisions of the Federal Code of Regulations are incorporated by reference

REFERENCE	TITLE
§ 1260.21	Compliance with OMB Circular A-110
§ 1260.22	Technical Publications and Reports
§ 1260.23	Extensions
§ 1260.24	Termination and Enforcement
§ 1260.25	Change in Principal Investigator or Scope
§ 1260.26	Financial Management
§ 1260.27	Equipment and Other Property
§ 1260.28	Patent Rights
§ 1260.29	Reserved
§ 1260.30	In full text
§ 1260.31	National Security
§ 1260.32	Nondiscrimination
§ 1260.33	Subcontracts
§ 1260.34	Clean Air and Water
§ 1260.35	Investigative Requirements
§ 1260.36	Travel and Transportation
§ 1260.37	Safety
§ 1260.38	Drug-Free Workplace
§ 1260.39	Buy American Encouragement
§ 1260.40	Investigation of Research Misconduct

Provisions listed above are contained in the Code of Federal Regulation (14 CFR Part 1260). The CFR can be accessed electronically at: <http://www.gpoaccess.gov/cfr/index.html> or copies are available in most libraries and for purchase from the Superintendent of Documents, Government Printing Office, Washington, D.C. 20402. Provisions incorporated by reference have the same force and effect as if they were given in full text. The full text provision can be found via the NASA Grant and Cooperative Agreement Handbook web site: [http://prod.nais.nasa.gov/pub/pub\\_library/grcover.htm](http://prod.nais.nasa.gov/pub/pub_library/grcover.htm). OMB Circulars referenced in the provisions can be assessed electronically at:

<http://www.whitehouse.gov/omb/circulars/> or may be obtained from the Office of Administration, Publications Unit, New Executive Office Building, Washington, D.C. 20503. An index of existing OMB Circulars is contained in 5 CFR 1310.

## Appendix D: Certifications and Assurances

### CERTIFICATION REGARDING DEBARMENT, SUSPENSION, AND OTHER RESPONSIBILITY MATTERS PRIMARY COVERED TRANSACTIONS

---

This certification is required by the regulations implementing Executive Order 12549, Debarment and Suspension, 34 CFR Part 85, Section 85.510, Participants' responsibilities. The regulations were published as Part VII of the May 28, 1988 Federal Register (pages 19160-19211). Copies of the regulations may be obtained by contacting the U.S. Department of Education, Grants and Contracts Service, 400 Maryland Avenue, S.W. (Room 3633 GSA Regional Office Building No. 3), Washington, D.C. 20202-4725, telephone (202) 732-2505.

A. The applicant certifies that it and its principals:

- (a) Are not presently debarred, suspended, proposed for debarment, declared ineligible, or voluntarily excluded from covered transactions by any Federal department or agency;
- (b) Have not within a three-year period preceding this application been convicted or had a civil judgment rendered against them for commission of fraud or a criminal offense in connection with obtaining, attempting to obtain, or performing a public (Federal, State, or Local) transaction or contract under a public transaction; violation of Federal or State antitrust statutes or commission of embezzlement, theft, forgery, bribery, falsification or destruction of records, making false statements, or receiving stolen property;
- (c) Are not presently indicted for or otherwise criminally or civilly charged by a government entity (Federal, State, or Local) with commission of any of the offenses enumerated in paragraph A.(b) of this certification; and
- (d) Have not within a three-year period preceding this application/proposal had one or more public transactions (Federal, State, or Local) terminated for cause or default; and

B. Where the applicant is unable to certify to any of the statements in this certification, he or she shall attach an explanation to this application.

C. Certification Regarding Debarment, Suspension, Ineligibility and Voluntary Exclusion - Lowered Tier Covered Transactions (Subgrants or Subcontracts)

- (a) The prospective lower tier participant certifies, by submission of this proposal, that neither it nor its principles is presently debarred, suspended, proposed for debarment, declared ineligible, or voluntarily excluded from participation in this transaction by any Federal department of agency.
- (b) Where the prospective lower tier participant is unable to certify to any of the statements in this certification, such prospective participant shall attach an explanation to this proposal.

---

Organization Name

---

Printed Name and Title of Authorized Representative

---

Signature

---

Date

---

Printed Name of Principal Investigator/Program Director

---

Proposal Title

## CERTIFICATION REGARDING LOBBYING

---

As required by S 1352 Title 31 of the U.S. Code for persons entering into a grant or cooperative agreement over \$100,000, the applicant certifies that:

(a) No Federal appropriated funds have been paid or will be paid by or on behalf of the undersigned, to any person for influencing or attempting to influence an officer or employee of any agency, a Member of Congress, in connection with making of any Federal grant, the entering into of any cooperative, and the extension, continuation, renewal, amendment, or modification of any Federal grant or cooperative agreement;

(b) If any funds other than Federal appropriated funds have been paid or will be paid to any person for influencing or attempting an officer or employee of any agency, Member of Congress, an or an employee of a Member of Congress in connection with this Federal grant or cooperative agreement, the undersigned shall complete Standard Form - LLL, "Disclosure Form to Report Lobbying," in accordance with its instructions.

(c) The undersigned shall require that the language of this certification be included in the award documents for all subawards at all tiers (including subgrants, contracts under grants and cooperative agreements, and subcontracts), and that all subrecipients shall certify and disclose accordingly.

This certification is a material representation of fact upon which reliance was placed when this transaction was made or entered into. Submission of this certification is a prerequisite for making or entering into this transaction imposed by S1352, title 31, U.S. Code. Any person who fails to file the required certification shall be subject to a civil penalty of not less than \$10,000 and not more than \$100,000 for each such failure.

---

Organization Name

---

Printed Name and Title of Authorized Representative

---

Signature

Date

---

Printed Name of Principal Investigator/Program Director

---

Proposal Title

---

**Assurance of Compliance with the National Aeronautics and Space Administration Regulations Pursuant to Nondiscrimination in Federally Assisted Programs**

The \_\_\_\_\_

(Institution, corporation, firm, or other organization on whose behalf this assurance is signed, hereinafter called "Applicant.")

HEREBY AGREES THAT it will comply with Title VI of the Civil Rights Act of 1964 (P. L. 88-352), Title IX of the Education Amendments of 1972 (20 U.S.C. 1680 et seq.), Section 504 of the Rehabilitation Act of 1973, as amended (29 U.S.C. 794), and the Age Discrimination Act of 1975 (42 U.S.C. 16101 et seq.), and all requirements imposed by or pursuant to the Regulation of the National Aeronautics and Space Administration (14 CFR Part 1250) (hereinafter called "NASA") issued pursuant to these laws, to the end that in accordance with these laws and regulations, no person in the United States shall, on the basis of race, color, national origin, sex, handicapped condition, or age be excluded from participation in, be denied the benefits of, or be otherwise subjected to discrimination under any program or activity for which the Applicant receives federal financial assistance from NASA; and HEREBY GIVES ASSURANCE THAT it will immediately take any measure necessary to effectuate this agreement.

If any real property or structure thereon is provided or improved with the aid of federal financial assistance extended to the Applicant by NASA, this assurance shall obligate the Applicant, or in the case of any transfer of such property, any transferee, for the period during which the real property or structure is used for a purpose for which the federal financial assistance is extended or for another purpose involving the provision of similar services or benefits. If any personal property is so provided, this assurance shall obligate the Applicant for the period during which it retains ownership or possession of the property. In all other cases, this assurance shall obligate the Applicant for the period during which the federal financial assistance is extended to it by NASA.

THIS ASSURANCE is given in consideration of and for the purpose of obtaining any and all federal grants, loans, contract, property, discounts or other federal financial assistance extended after the date hereof to the Applicant by NASA, including installment payments after such date on account of applications for federal financial assistance which were approved before such date. The Applicant recognizes and agrees that such federal financial assistance will be extended in reliance on the representations and agreements made in this assurance, and that the United States shall have the right to seek judicial enforcement of this assurance. This assurance is binding on the Applicant, its successors, transferees, and assignees, and the person or persons whose signatures appear below are authorized to sign on behalf of the Applicant.

\_\_\_\_\_  
Organization Name

\_\_\_\_\_  
Printed Name and Title of Authorized Representative

\_\_\_\_\_  
Signature

\_\_\_\_\_  
Date

\_\_\_\_\_  
Printed Name of Principal Investigator/Program Director

\_\_\_\_\_  
Proposal Title